

## SUMITOMO RECOMMENDED PROCEDURE

### SRP SP-F02-011

#### Ribbon Splitting Procedure (RS-24)

<u>PARA.</u>	<u>CONTENTS</u>
1.0	General
2.0	Safety Precautions
3.0	Reference Documents
4.0	Tools Required
5.0	Ribbon Splitting Procedure
6.0	Splitter Tool Cleaning



**SUMITOMO ELECTRIC LIGHTWAVE CORP.**

201 South Rogers Lane, Suite 100, Raleigh, NC 27610

(919) 541-8100 or 1-800-358-7378

[www.sumitomoelectric.com.com](http://www.sumitomoelectric.com.com)

SEL is a Member of the Sumitomo Electric Industries, Ltd. Group

*Sumitomo Electric Lightwave reserves the right to improve or modify these specifications without notice.*

## 1.0 General

Demand for higher fiber count cables has resulted in the utilization of higher fiber count ribbons. Ribbons contain multiple, individually colored, 250 µm optical fibers arranged in a flat linear matrix encapsulated by an UV cured polymer material. The 24-fiber ribbon is emerging as the most popular high-count size.

This document describes the procedure for dividing a 24-fiber ribbon into two (2) 12-fiber ribbons in either mid-span or end entry. After dividing, the 12-fiber ribbons can be mass spliced or otherwise terminated the same as standard 12-fiber ribbons.

## 2.0 Safety Precautions

The use of safety eyeglasses is strongly recommended when handling optical fibers and ribbons. Ensure adequate ventilation when using isopropyl alcohol.

## 3.0 Reference Documents

- SP-F02-004 ARMORLUX™ Cable
- SP-F02-005 ADS™ Cable
- SP-F02-006 Cable Mid-Span Access
- SP-F02-007 Ribbon Access Procedures
- SP-F03-005 Ribbon Unit Splitter Installation

## 4.0 Tools Required

The following tools and materials are required to complete this procedure.

1. Ribbon Splitter Tool (part no. RS-24)
2. Isopropyl Alcohol (not included)

## 5.0 Ribbon Splitting Procedure

**NOTE:** This procedure assumes that a Sumitomo Recommended Procedure (SP-F02-004 to SP-F02-006) or other appropriate cable cleaning procedure has already been followed and the cable is prepared with ribbons exposed.

### 5.1 End Access

5.1.1 Clean the 24-fiber ribbon thoroughly with isopropyl alcohol. Cut a 'clean' edge to remove any frayed length from the ribbon end.

5.1.2 The ribbons can be easily split in end access by hand. Hold one half of the ribbon width in each hand. Gently flex the two halves in opposite directions to initiate the split. The ribbon will separate into two 12-fiber ribbons.

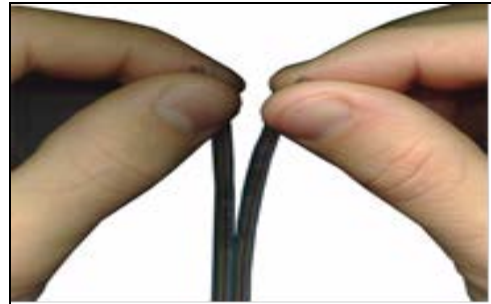

Figure 1

5.1.3 Continue pulling the two 12-fiber ribbons toward opposite directions until the desired split length is attained.

**NOTE:** After splitting, each 12-fiber ribbon retains its own unique number, marked on the ribbon surface, for the purposes of unit identification.

### 5.2 Mid-Span Access

5.2.1 Clean the 24-fiber ribbon thoroughly with isopropyl alcohol. Make sure that knob is pushed in to the open position, fully exposing the slot.

5.2.2 Insert the ribbon into the slot in the Ribbon Splitter Tool. Ensure the ribbon is fully seated into the slot. Rotate the ribbon clamps located on each end of the tool so the flange holds the ribbon in the slot.

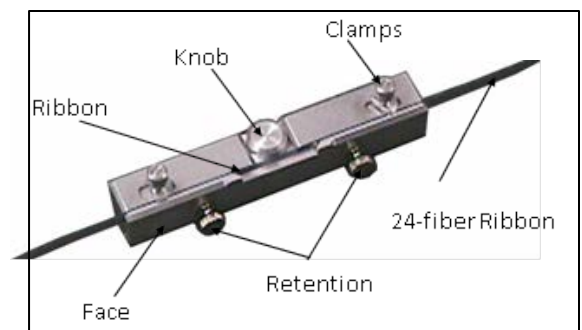

Figure 2

5.2.3 Slide the round knob located in the center of the tool towards the ribbon finishing at the 'closed' position beyond the ribbon slot. This sliding action splits the 24-fiber ribbon into two 12-fiber ribbons.



**Figure 3**

5.2.4 To remove the ribbon from the tool, move the round knob back to the 'open' position, rotate the ribbon clamps to open, and lift the ribbon out. The splitting can now be continued by hand over the desired length.

## **6.0 Splitter Tool Cleaning**

6.1 Remove the front faceplate by unscrewing the two retention screws on the front of the tool. The faceplate should come apart from the splitter tool.

6.2 With cotton gauze and isopropyl alcohol, clean the Ribbon Slot on the splitter tool, and all areas in contact with the ribbon on the faceplate. Dirt and impurities in the Ribbon Slot can prevent the ribbon from being properly inserted in the tool, resulting in a poor split.

6.3 After cleaning, attach the faceplate back on the splitter tool by screwing the retention screws back into the tool.